

MODEL 552H OSCILLOSCOPE

OPERATION MANUAL

キクスイ電子工業株式会社

KIKUSUI ELECTRONICS CORP.

Contents

	Page
General	3
Specifications	4
Front Panel	7
Rear Panel	11
Operating Procedure	13
Measuring Procedure	16
1. Measurement of phase difference	16
2. Frequency measurement	18
Maintenance	20
Adjustment of vertical axis DC balance	20
Adjustment of horizontal axis DC balance	21
Adjustment of astigmatism	22
Removal of case	22
Adjustment of power voltage	24
Adjustment of CAL mV_{p-p} (calibration voltage)	25
Adjustment of trace center	25

General:

Kikusui Electronics' Model 552H is an x-y oscilloscope to be used in combination with a sweep generator for direct-viewing the frequency response of measuring instruments. The 552H is designed to be compact by using a cathode-ray tube 133 mm in screen diameter. The circuitry uses semi-conductors to the full extent, and balanced DC amplifiers of high sensitivity and stability. Compared with the vacuum-tube oscilloscope, the 552H has less drift and higher reliability.

Provided with a line sweep, the 552H is suitable for use in a mass-production line which employs a concentrated type sweep generator. Also, the 552H is widely usable as it includes a high-sensitivity z-axis (intensity modulation) terminal, a pulse marker terminal, a variable resistor for adjusting the amplitude of the marker pulse, a selector switch for changing over the polarity of the pulse marker signal and a sensitivity calibration voltage of stabilized square wave.

Horizontal Axis

Sensitivity	More than 200 mV _{p-p} /cm
Frequency Response	AC Less than -3 dB at 2 Hz to 50 kHz DC Less than -3 dB at 0 to 50 kHz
Input Impedance	Approx. 220 k Ω ; parallel capacity, less than 30 pF
Input Terminal	UHF-type receptacle (also applicable to M-type)
Allowable Input Voltage	100 V (peak value including DC compo- nent) for a frequency less than 1 kHz
Line Sweep Built In	Phase variation range: Approx. 130°
Calibration Voltage	
Output Voltage	5, 10 and 20 mV _{p-p} line frequency square waves
Accuracy	$\pm 5\%$
Miscellaneous	
Cathode-ray Tube	133 m/m round type cathode-ray tube
Phosphor	P1 (Green)
Acceleration Voltage	Approx. 1300 V
Effective Screen Area	8 x 10 cm

Accessories

Model 941B Terminal Adapter	1
Operation Manual	1

Marker input (selectable either intensity modulation or pulse marker)

Intensity Modulation

System Z-axis intensity modulation

Sensitivity	Sufficient modulation obtained with 300 mV _{p-p} signal at a frequency 1 kHz by an internal amplifier.
Frequency Response	Less than -3 dB at 100 Hz to 400 kHz.
Input Impedance	Approx. 220 kΩ; parallel capacitance, less than 60 pF.
Input coupling	AC coupled
Polarity of Modulation	Brightness increases with positive signal.
Allowable Input Voltage	100 V (peak value including DC component) for a frequency less than 1 kHz.
Pulse Marker	
Sensitivity	More than 300 mV _{p-p} /cm
Input Coupling	AC coupled
Input Impedance	Approx. 220kΩ; parallel capacitance, less than 60 pF.
Amplitude Control	Variable continuously down to infinitesimal with the AMPLITUDE knob.
Frequency Response	Less than -3 dB at 100 Hz to 200 kHz.
Allowable Input Voltage	100 V (peak value including DC component) for a frequency less tha 1 kHz.
Polarity	Positive-going or Negative-going selectable.

Front Panel:

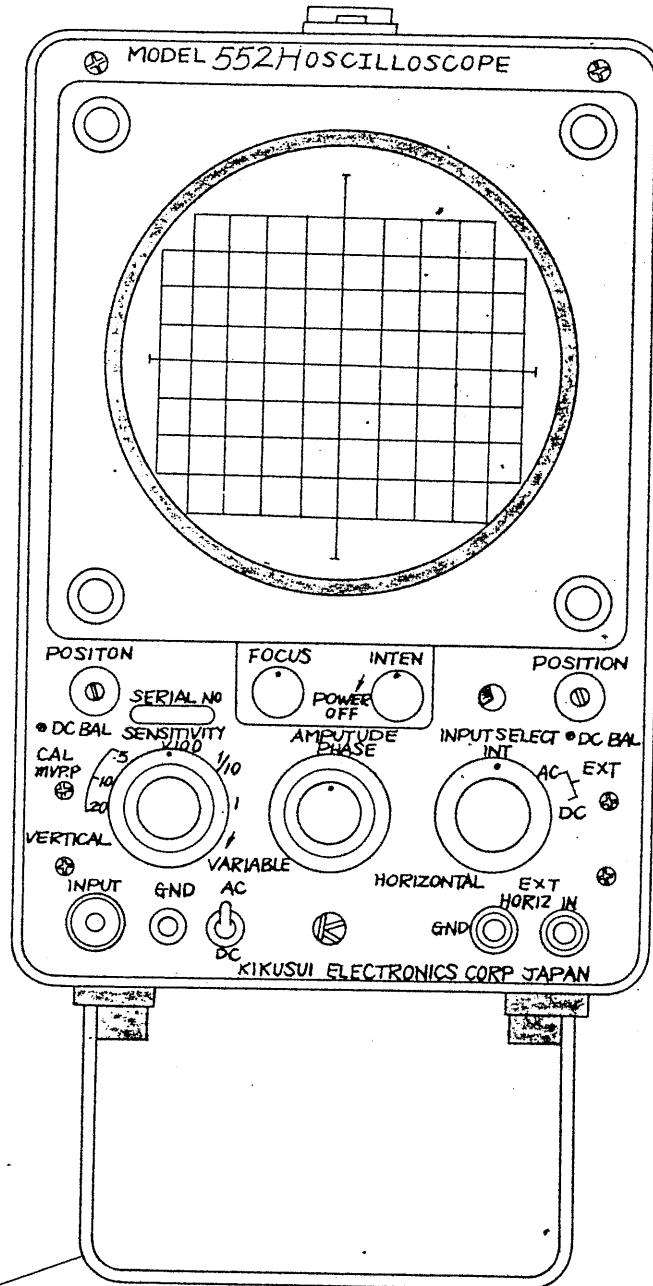

POWER OFF When this knob is turned full counterclockwise, power supply turns off. When turned clockwise from the above position, the knob clicks. Then power supply turns on, and the pilot lamp (neon) on the right side of the knob lights. This knob is also used for INTENSITY control..

INTEN Knob for controlling the brightness on CRT. As the knob is turned clockwise, the brightness increases. This knob is also used as the power switch.

FOCUS Knob for adjusting the focus on CRT. Turn the knob so that the trace becomes most clear and sharp.

VERTICAL

POSITION Knob for adjusting the trace position vertically.

DC BAL Screw located at the center of the POSITION knob. A semi-fixed variable resistor is provided for adjusting the DC balance of the vertical axis amplifier. Use a screwdriver for adjustment. Refer to "Adjustment of vertical axis DC balance," page 20.

INPUT Terminal for vertical axis input.

AC and DC Switch for changing over the vertical axis input to AC or DC coupling.

SENSITIVITY Outer black knob for selecting 1, 1/10 or 1/100 sensitivity by the input voltage divider of the vertical axis amplifier. When the knob is set to CAL 5, 10 or 20 mV_{p-p} position, the sensitivity calibration voltage inside the equipment is connected to the amplifier, and the sensitivity can easily be calibrated by using the VARIABLE knob.

VARIABLE Red knob for finely adjusting the sensitivity of the vertical axis amplifier. The sensitivity can be continuously adjusted to approximately 1/10.

HORIZONTAL POSITION Knob for adjusting the trace position horizontally.

DC BAL Screw located at the center of the POSITION knob. A semi-fixed variable resistor is provided for adjusting the DC balance of the horizontal axis amplifier. Use a screwdriver for adjustment. Refer to "Adjustment of horizontal axis DC balance," page 20.

EXT HORIZ IN Terminal for the external signal input for horizontal axis.

INPUT SELECT Switch for selection of internal or external

(AC or DC) horizontal axis input.

INT When the switch is set to this position, the horizontal axis input is connected to the line sweep inside the equipment.

EXT (AC/DC) Horizontal axis input is connected to the external input terminal. AC or DC coupling can further be selected.

AMPLITUDE Outer black knob for adjusting the sensitivity of the horizontal axis amplifier. The sensitivity can be continuously adjusted to approximately 1/10.

PHASE Red knob for adjusting the phase of internal line sweep. The phase is continuously adjustable from 0° to approximately 130°.

Rear Panel :

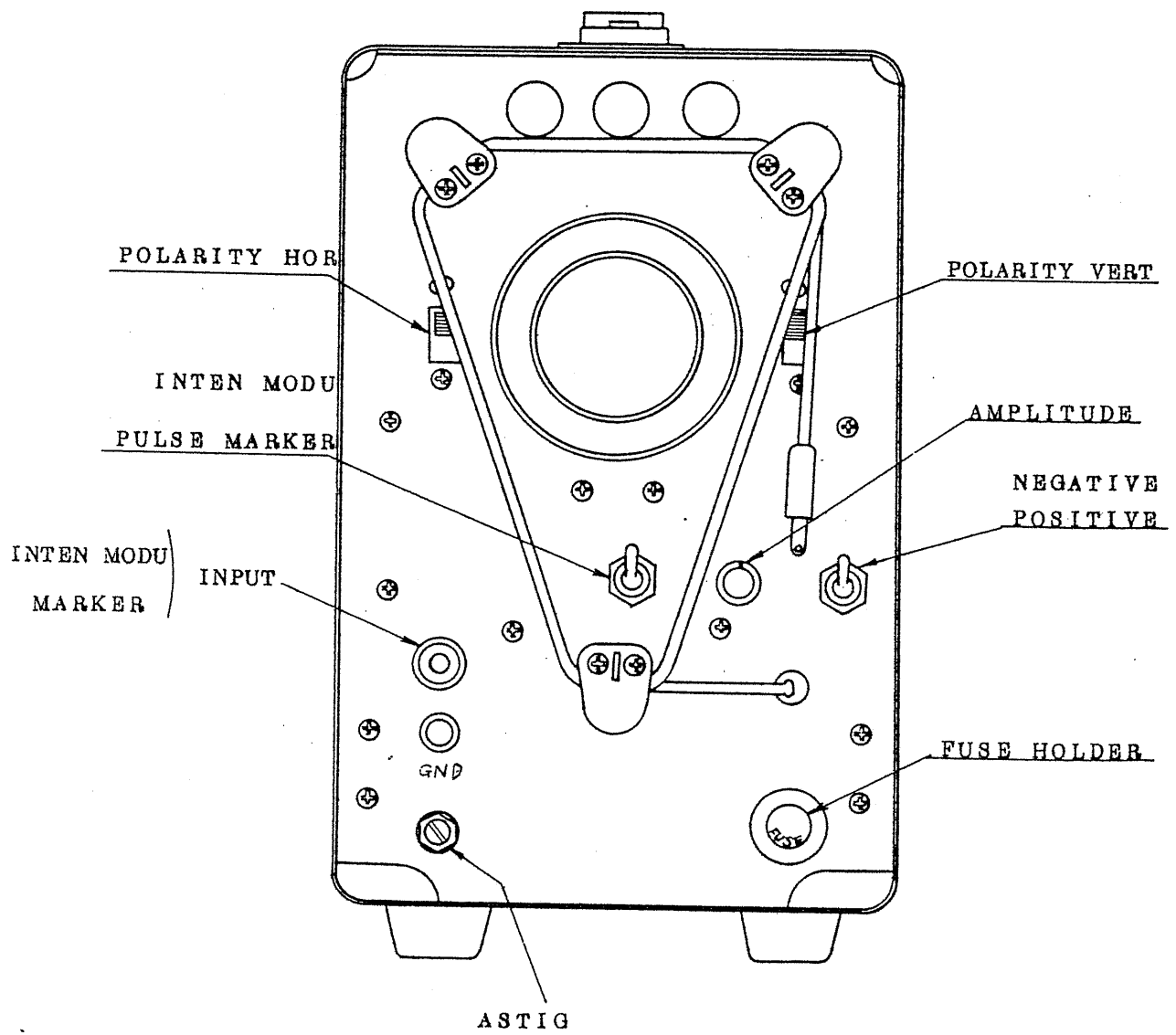

POLARITY VERT Switch for changing over the polarity of vertical axis. Set the switch to the lower position when desiring to reverse the polarity of trace waveform 180° vertically. For normal operation, keep the switch set to the upper position.

POLARITY HOR Switch for changing over the polarity of horizontal axis. Set the switch to the lower position when desiring to reverse the polarity of trace waveform 180° horizontally. For normal operation, keep the switch set to the upper position.

INTEN MODU) UNPUT Input terminal for Z-axis intensity modulation
MARKER signals or pulse marker signals.



Switch for selection of intensity modulation or pulse marker input.



AMPLITUDE

Knob for controlling the amplitude of marker pulse, As the knob is turned counterclockwise, the amplitude decreases continuously to infinitesimal.

POSITIVE



Switch for changing over the polarity of marker pulse correspond to the polarity of pulse signals from a sweep generator being in use.

Operating Procedure:

Line Voltage The 552H stably operates within a line voltage range of AC _____ V $\pm 10\%$

For the maximum reliability and part life, use the 552H at a line voltage as close to the center of the above voltage range as possible.

Installation

Install the 552H where the ambient temperature is within a range of 0 to 40° C.

Keep it from direct sunlight, moisture and dust. When using it near the equipment, machine or other object which generates heat, consider appropriate ventilation.

Other Cautions

If there is a strong magnetic field nearby, the electron beam in the CRT may be abnormally deflected by the field.

Also, noise may be picked up, and the trace distorted. Avoid using the 552H where corrosive gas exists. Such gas greatly shortens the life of electronic parts in the 552H.

Allowable Input Voltage

Do not apply voltages in excess of the maximum values listed below, to the vertical axis and horizontal axis input terminals. When a voltage higher than the maximum value is applied, the input attenuator and other parts may be damaged.

Vertical axis input terminal:

400 V at maximum (peak value including DC component) for a frequency less than 1 kHz at 1/1 range.

600 V at maximum (peak value including DC component) for a frequency less than 1 kHz at 1/10 & 1/100 range.

Horizontal axis input terminal:

100 V at maximum (peak value including DC component) for a frequency less than 1 kHz.

Use of INTEN MODU and PULSE MARKER

INTEN MODU Set the INTEN MODU, PULSE MARKER switch to INTEN MODU and connect the intensity modulation signal to the M-type receptacle located on the rear panel. The input voltage needed for modulation is 300 mV_{p-p} or more. The waveform may be pulse or sine wave, and the voltage polarity may be either positive or negative. Adjust the INTEN knob slightly for the best modulation and image clearness.

PULSE MARKER Set the INTEN MODU, PULSE MARKER switch to PULSE MARKER and connect the signal pulse to the M-type receptacle located on the rear panel. Signal pulses of 300 mV_{p-p} or more amplitude make marker pulse figure of 1 cm or more height on the fluorescent screen of the cathode-ray tube. Control the AMPLITUDE knob for obtaining a suitable height of the marker pulse figure. Also, changeable over the polarity of the marker pulse on the fluorescent screen of the cathode-ray tube with the POSITIVE, NEGATIVE switch.

POSITIVE GOING
PULSE
MARKER SIGNAL

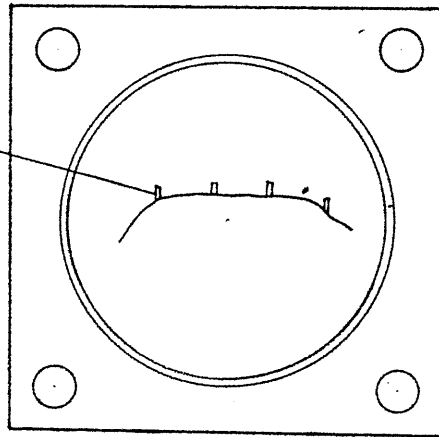

NEGATIVE GOING
PULSE
MARKER SIGNAL

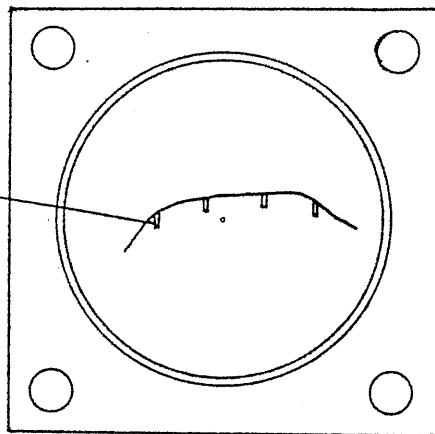

Measuring Procedure :

1. Measurement of phase difference

The phase difference between two signals of the same frequency is measured by utilizing a Lissajous figure. Before starting this measurement, measure the intrinsic phase difference existing between the vertical and horizontal amplifiers in the 552H since such phase difference cannot be neglected at certain frequencies.

Set the HORIZONTAL INPUT SELECT switch to the EXT AC or DC position, apply the sine wave output of a low-frequency signal generator to the vertical and horizontal input terminals as illustrated below, and measure the intrinsic phase difference of the 552H.

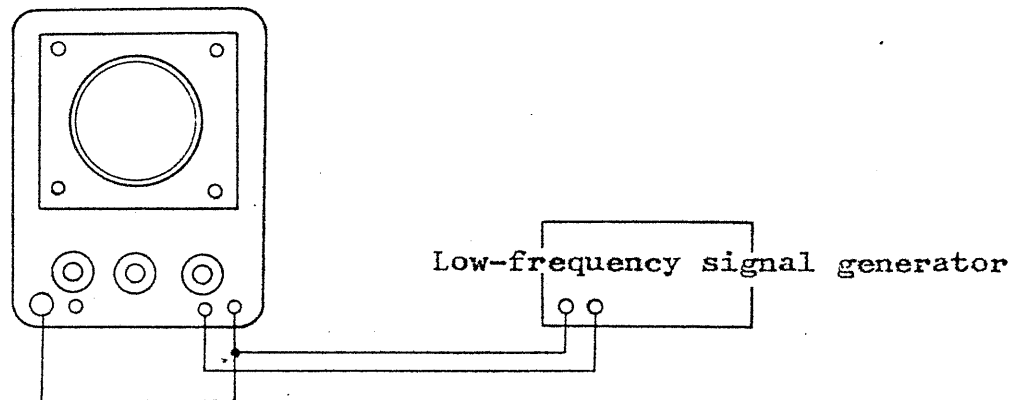

Adjust the SENSITIVITY switch, and VARIABLE AND AMPLITUDE knobs so that a figure of appropriate size is traced on the screen as shown below. Vary the frequency of the low-frequency signal generator, then a loop figure will be formed as shown at a frequency of several tens of kilohertz.

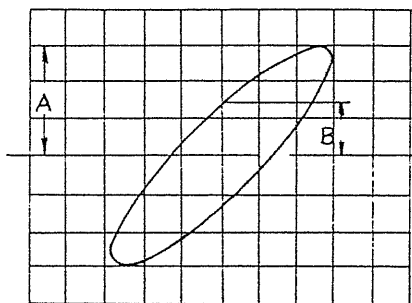

The intrinsic phase difference can be obtained as follows:
Set the horizontal and vertical amplitudes of the loop figure to the scale as shown above, read values A and B, and calculate the phase difference angle by using the following formula:

$$\text{Phase difference angle} = \sin^{-1} \frac{B}{A}$$

This phase difference angle measuring method can be applied to, for example, the measurement of phase difference between input and output of an amplifier, as illustrated below. The true phase difference is the intrinsic phase difference angle of the amplifier subtracted from the phase difference angle measured.

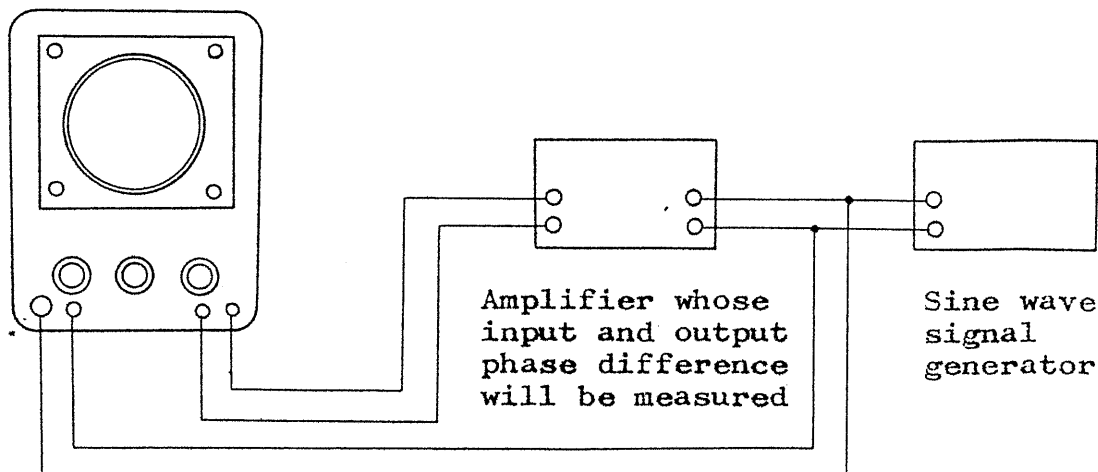

2. Frequency measurement

A Lissajous figure can be obtained on the CRT when two kinds of AC voltages are applied to the vertical and horizontal axes simultaneously. By utilizing the figure and a known reference frequency, the unknown frequency of the signal applied can be measured. A connection diagram for this measurement is shown below:

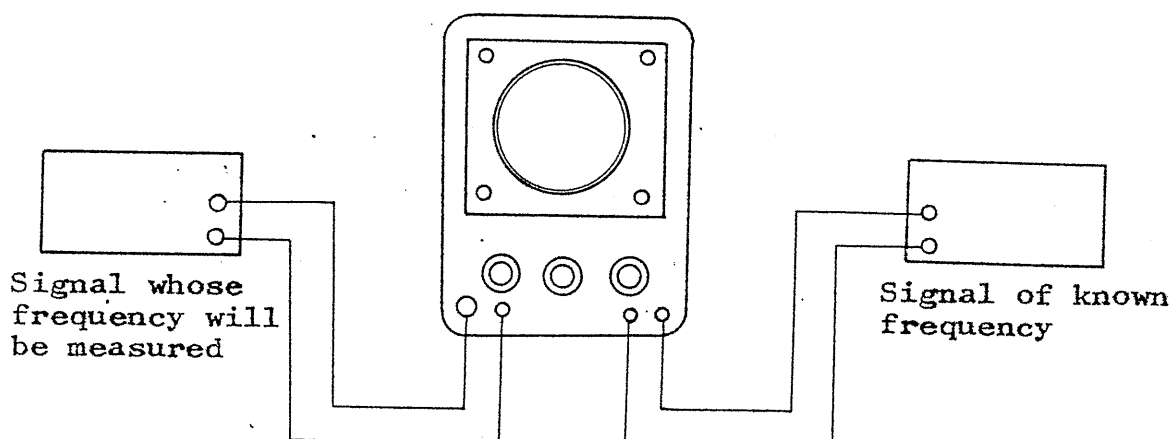

When the ratio of vertical frequency to horizontal frequency is integral in value, the figure on CRT stops showing one of the patterns illustrated below.

Count the number (N_V) of the points where the loop is in contact with vertical tangents, and the number (N_h) of the points where the loop is in contact with horizontal tangents. Then the vertical and horizontal input frequencies f_V and f_h can be obtained by using the following formula:

$$\frac{f_V}{f_h} = \frac{N_h}{N_V}$$

Two different values may be obtained for N_V and N_h , respectively, depending on the phase relationship between the two signals, as shown below. The figures in the upper row and the figures immediately below them correspond to each other, respectively.

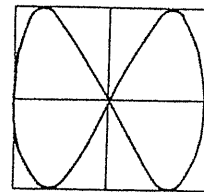
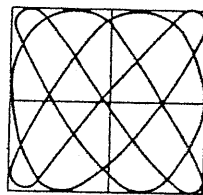
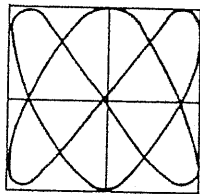
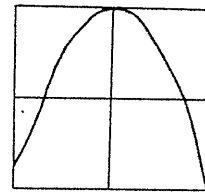
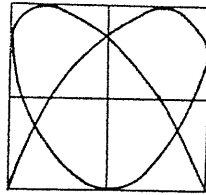
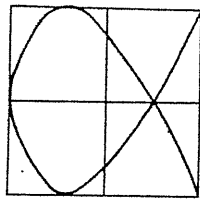

$$\frac{f_V}{f_n} = \frac{3}{2}$$

$$\frac{f_V}{f_n} = \frac{4}{3}$$

$$\frac{f_V}{f_n} = \frac{2}{1}$$

Maintenance:

Adjustment of vertical axis DC balance

Conduct this adjustment 15 to 20 minutes after the 552H is energized.

1. Short the vertical input and GND terminals between them.
2. Turn the SENSITIVITY VARIABLE knob full counterclockwise, and set the trace to the center of the scale by turning the vertical POSITION knob.
3. Turn the VARIABLE knob full clockwise. If the trace shifts upward or downward when the knob is thus turned, vertical DC balance is maladjusted.

Correct the DC balance as follows:

4. Leave the VARIABLE knob turned full clockwise, and turn the DC BAL screw with a screwdriver to adjust the trace to the center of the scale.
5. Turn the VARIABLE knob full clockwise and counterclockwise alternately. If the trace still shifts then, finely adjust the DC BAL screw. Repeat the above adjusting procedure until the trace does not shift when the VARIABLE knob is turned.

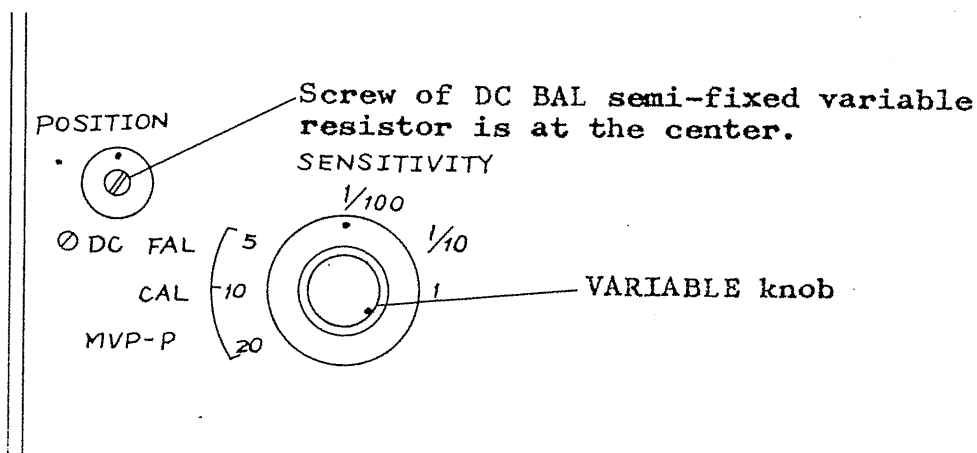

Adjustment of horizontal axis DC balance

Conduct this adjustment 15 to 20 minutes after the 552H is energized.

1. Short the horizontal input and GND terminals between them, and set the INPUT SELECT switch to EXT AC or DC.
2. Turn the AMPLITUDE knob full counterclockwise, and set the trace to the center of the scale by turning the horizontal POSITION knob.
3. Turn the AMPLITUDE knob full clockwise. If the trace shifts rightward or leftward when the knob is thus turned, horizontal DC balance is maladjusted.

Correct the DC balance as follows:

4. Leaving the AMPLITUDE knob turned full clockwise, turn the DC BAL screw with a screwdriver to adjust the trace to the center of the scale.
5. Turn the AMPLITUDE knob full clockwise and counterclockwise alternately. If the trace still shifts then, finely adjust the DC BAL screw. Repeat the above adjusting procedure until the trace does not shift when the AMPLITUDE knob is turned.

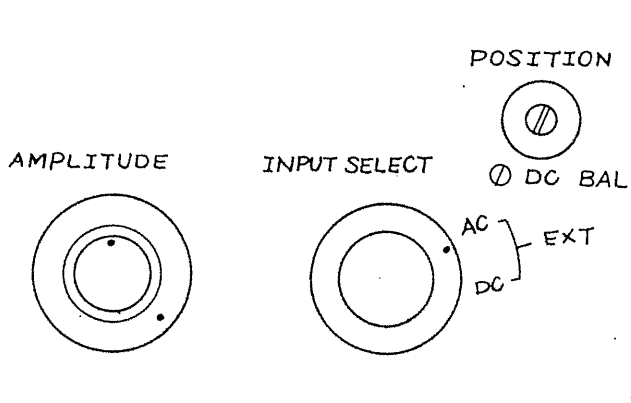

Adjustment of astigmatism

Conduct this adjustment with the ASTIG semi-fixed variable resistor located on the rear panel.

1. Let the 552H trace a waveform.
2. Adjust the ASTIG screw and the FOCUS knob on the front panel so that the trace has a uniform thickness over the entire scale and has the highest sharpness and clearness.

Removal of case

Remove the two screws located on both sides, respectively, of the equipment case, and the screw located on the bottom.

(Locations of the screws are illustrated below.)

Then gently pull out the front panel and chassis together.

Be sure to deenergize the 552H before removing the case, since high voltages are exposed at various points in the equipment.

Two screws on
this side

Screw on bottom

Two screws
on this
side

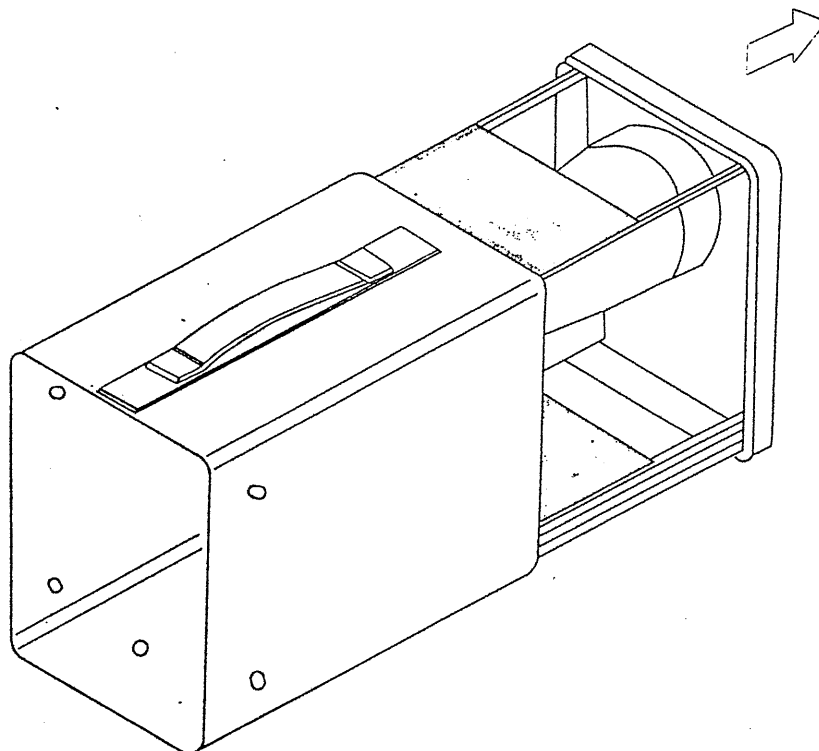

Adjustment of power voltage

Two power supply systems for regulated +12 and -9 V are provided as shown in the attached drawing "Power Supply and CRT Circuit."

The +12 V is adjustable with semi-fixed resistor R318.

Although a semi-fixed resistor is not provided for adjustment of the -9 V, this voltage is automatically set to approximately -9 V when the +12 V is adjusted. The location of semi-fixed resistor R318 is shown below.

For checking output voltage, measure the voltage between the test point marked "+12 V" or "-9 V" on the printed circuit board, and the ground.

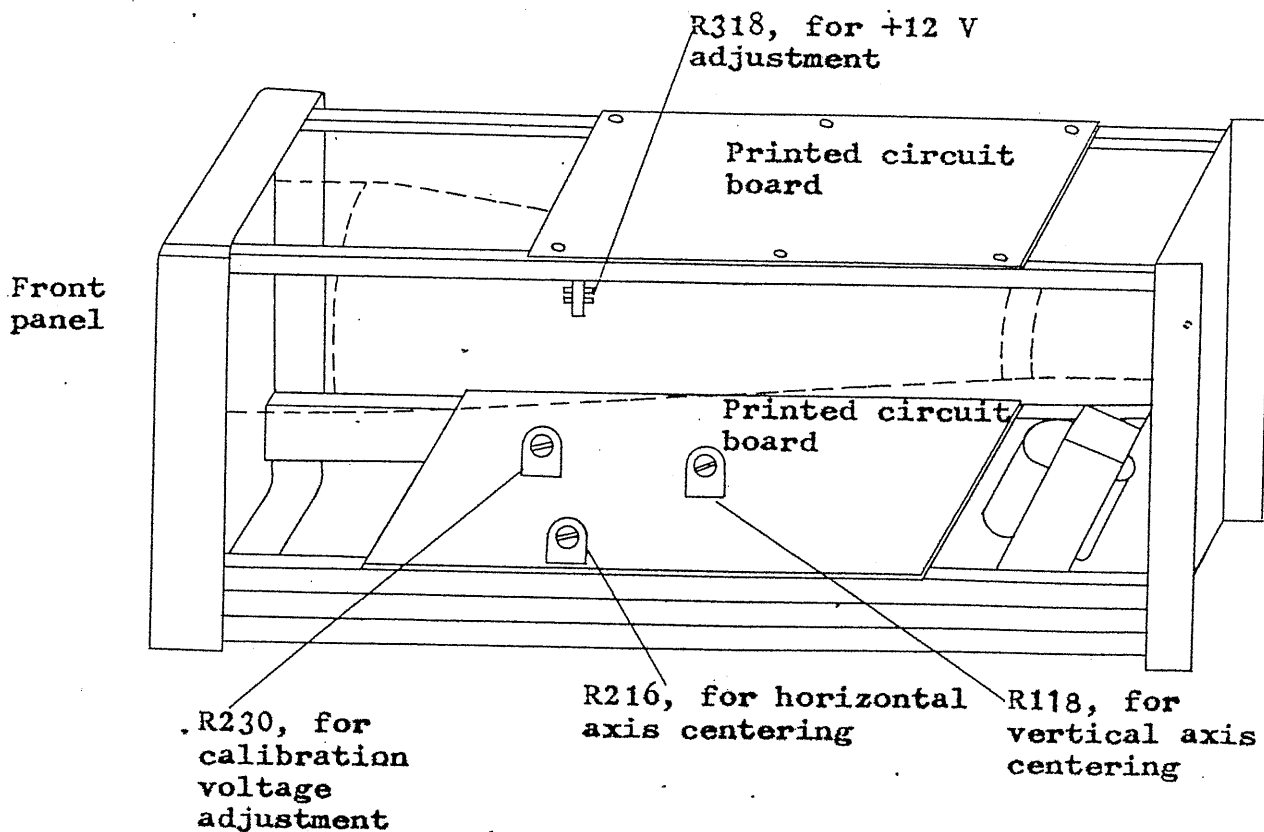

Adjustment of CAL mV_{p-p} (calibration voltage)

Adjustment of calibration voltage is seldom needed since the power source of the calibration voltage generator circuit is stabilized by using a reference diode. When adjustment should be necessary, adjust semi-fixed resistor R230 so that the voltage at the joint of R230 and R231 is $2V_{p-p}$. For this voltage observation, an oscilloscope or p-p indication type voltmeter whose voltage sensitivity has been accurately calibrated should be connected to the joint of the above resistors.

Refer to the attached circuit diagram.

Adjustment of trace center

Semi-fixed variable resistors R118 and R216 are provided for centering the trace on the CRT screen, with the vertical and horizontal POSITION knobs set to the middle of their turning, range, respectively.

Without applying input signal, set both POSITION knobs to the middle of their turning range as illustrated below.

If the trace or spot on the CRT screen is off the center upward or downward, adjust it with R118; if rightward or leftward, with R216.

The above adjustment does not affect vertical and horizontal DC balance at all.

POSITION

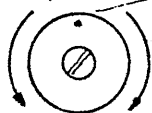

⊙ DC BAL

The knob is in the middle of its turning range when the white dot or line on the knob is at the top.

For the locations of semi-fixed resistors R118 and R216, refer to the illustration under "Adjustment of power voltage," page 23.